

# On-chip characterization of RF systems based on envelope response analysis

Manuel J. Barragán, Raffaella Fiorelli, Diego Vázquez, Adoración Rueda,  
José L. Huertas

A simple on-chip procedure for testing embedded RF blocks is presented. It is based on the detection and spectral analysis of the two-tone response envelope of the Device Under Test (DUT). The main non-linearity specifications of the DUT can be easily estimated from the envelope signal without the need of expensive RF test equipment.

*Introduction:* Nowadays, the advance in RF CMOS technologies has enabled the integration of complete transceivers in a single chip, which provides a significant reduction in manufacturing cost. However there is a simultaneous increase in the cost of testing and diagnosis of these devices. Their diverse specifications and high operating frequency, as well as the large impact of process variations in current deep sub-micron technologies, make necessary extensive tests, both complex and expensive to perform. Reducing RF test complexity and cost is still an open research topic that has been addressed in a number of different approaches. Recent work in this area includes defect modeling and failure diagnosis [1], alternate test [2], Design for Test (DfT) and Built-In-Self-Test (BIST) techniques [3]-[6], etc.

In particular, BIST techniques have been identified as a solution to mitigate several RF test drawbacks [5]. In this context, the work in [6] proposes the use of a very simple envelope detector for RF test purposes. This reference

demonstrates that selected specifications of an RF block can be extracted from the envelope of its response to an optimized test stimulus. The envelope is acquired with a standard A/D converter and processed to carry out the demanded measurements. Nevertheless, the method relies in a complex optimization algorithm to find the optimum test stimulus, complemented with the use of a multivariate-adaptive regression splines mapping for extracting the target specifications from the digitized envelope response.

The proposal to be described herein aims to extend the idea of testing by an envelope response characterization, but unlike [6], it is directly based on analytical results, avoiding the need of complex stimulus optimization and regression models, and hence, eliminating the pre-processing stage. Furthermore, it will be demonstrated that processing the envelope can be greatly simplified by using a simple technique based on first-order  $\Sigma\Delta$  modulation for acquiring the envelope instead of a complete A/D converter.

*Traditional test method:* Fig. 1a shows a standard two-tone test set-up, traditionally used to characterize RF systems. In this test scheme, two high-frequency close tones at frequencies  $\omega_0 \pm \omega_b/2$  (where  $\omega_b \ll \omega_0$ ) are used as test stimuli and fed to the DUT. The system response is then acquired and conveniently processed to extract important performance parameters such as forward gain, 3rd-order Intercept Point (IP3), inter-modulation products, 1-dB compression point, etc [7]. However the direct acquisition and processing of the test response is a challenging task, since this response is a high frequency signal, handled necessarily by expensive RF test equipment.

*Proposed test method:* Our approach, represented in Fig. 1b, is similar to the traditional scheme, but in this case the DUT response drives an envelope detector. The extracted envelope has information about the test response at much lower frequencies ( $\omega_b \ll \omega_0$ ), this information being easily extracted by simple processing. In what follows it will be explained how the DUT response information is encoded in its envelope, and how it can be extracted.

Let us consider a non-linear RF device driven by a signal  $x(t)$  composed by two equal-magnitude tones at different, but very close, frequencies, as,

$$x(t) = A \cos((\omega_0 - \omega_b / 2)t) + A \cos((\omega_0 + \omega_b / 2)t) \quad (1)$$

where  $A$  is the amplitude of each test tone and  $\omega_b$  is the frequency difference between them. Assuming, as it is the case in most situations, a third-order non-linear model for the RF block, the response  $y(t)$  can be expressed, discarding out-of-band components, as,

$$y(t) \cong B_1 \cos((\omega_0 - \omega_b / 2)t) + B_1 \cos((\omega_0 + \omega_b / 2)t) + B_2 \cos((\omega_0 - 3\omega_b / 2)t) + B_2 \cos((\omega_0 + 3\omega_b / 2)t) \quad (2)$$

Let  $R(t)$  be the envelope of the response signal  $y(t)$ . Using the Rice formulation [8],  $R(t)$  can be derived as

$$R(t) = |2B_1 \cos(\omega_b t / 2) + 2B_2 \cos(3\omega_b t / 2)| \quad (3)$$

Signal  $R(t)$  results to be a periodical signal with period  $T_b = 2\pi / \omega_b$  and hence, can be expanded in its Fourier series as

$$R(t) = b_0 + \sum a_k \sin(k\omega_b t) + b_k \cos(k\omega_b t) \quad (4)$$

where  $a_k = 0$ ,  $b_0 = 4/\pi(B_1 - B_2/3)$ , and coefficients  $b_k$  are given by,

$$b_k = \frac{8}{\pi} \left( \frac{B_1 (-1)^{k+1}}{4k^2 - 1} + \frac{3B_2 (-1)^k}{4k^2 - 9} \right) \quad k = 1, 2, \dots \quad (5)$$

Equation (5) shows that every harmonic component of  $R(t)$  is a linear combination of the magnitudes  $B_1$  and  $B_2$ , and hence, they can be derived from the frequency components of  $R(t)$ .

As the response envelope is a low-frequency periodic signal, its spectral analysis can be computed using the efficient method proposed by the authors in [9], which combines square-wave and first-order  $\Sigma\Delta$  modulation together with very simple digital operations to decompose the signal into a set of digital spectral signatures. Applying the procedure in [9], a set of signatures  $\Lambda_k$  encoding the magnitude of the harmonic components of  $R(t)$  are obtained as

$$\begin{aligned}\Lambda_k &= \frac{2MN}{\pi} \left( |b_k| + \frac{1}{3}|b_{3k}| + \frac{1}{5}|b_{5k}| + \dots \right) \pm 2 \cong \frac{2MN}{\pi} |b_k| = \\ &= \frac{2MN}{\pi} \frac{8}{\pi} \left| \frac{B_1}{4k^2 - 1} - \frac{3B_2}{4k^2 - 9} \right| \pm 2 \quad k = 1, 2, \dots\end{aligned}\tag{6}$$

where  $M$  is the number of periods of  $R(t)$  taken in the evaluation,  $N$  is the number of evaluated samples per period, the error term  $\pm 2$  is due to the quantization error in the  $\Sigma\Delta$  modulators, and magnitudes  $b_k$ ,  $B_1$ , and  $B_2$  are in this case normalized to the Full-Scale (FS) of the modulators. This way it is possible to estimate the magnitude of every harmonic component of  $R(t)$ , within the limits imposed by the quantization error, and without the need of a full A/D converter and complex FFT algorithms. Magnitudes  $B_1$  and  $B_2$  are computed through signatures  $\Lambda_1$  and  $\Lambda_2$  (the most significant ones) by solving (6). It is important to notice that as (6) has been approximated by neglecting the contribution of high-order harmonics ( $b_{3k}$ ,  $b_{5k}, \dots$ ) to signatures  $\Lambda_k$ , a certain deviation is then expected in the measurement. However, in any case, this deviation can be reduced by considering the complete expression at the cost of more complex processing.

*Simulation results:* The proposed characterization approach has been validated by behavioral simulations in Verilog-A. The objective of these simulations is the characterization of the non-linear behavior of a typical RF block in terms of the ratio  $B_2/B_1$ . For this example a Low Noise Amplifier (LNA) has been used as DUT. The LNA under test is driven by a two-tone at-speed stimulus, and its response envelope is extracted and processed as explained in the previous section. In this simulation the envelope detector has been modeled by a typical diode-based detector shown in Fig. 2. Table I lists the simulation parameters. The simulation results are listed in Table II for different number of evaluation periods,  $M$ . As predicted by (6), the estimated confidence interval for the  $B_2/B_1$  ratio narrows as  $M$  increases: it goes from  $(-\infty, -36\text{dB}]$  for  $M=5$  to  $[-53\text{dB}, -48\text{dB}]$  for  $M=100$ . It is interesting to notice that for  $M=100$  the effect of neglecting high-order components deviates the estimation from the actual value of  $-56\text{dB}$  by only  $3\text{dB}$ , which is accurate enough for most RF test applications.

*Conclusions:* A novel methodology for the characterization of the non-linear characteristic of embedded RF blocks has been presented. It is based on the analysis of the envelope of the device response to a two-tone at-speed stimulus. The required test hardware is reduced to an envelope detector together with simple first-order  $\Sigma\Delta$  modulators, eliminating the need of high-frequency signal processing and standard A/D conversion. This makes the proposal very suitable for BIST applications.

## References

- 1 E. Acar, S. Ozev, "Defect-based RF testing using a new catastrophic fault model", IEEE International Test Conference, Nov. 2005.
- 2 A. Halder, S. Bhattacharya, G. Srinivasan, A. Chatterjee, "A system level alternate test approach for specification test of RF transceivers in loopback mode", Proc. VLSI design, 2005.
- 3 J. Ryu, B. C. Kim, I. Sylla, "A new low-cost RF BIST measurement for SoC transceivers", IEEE Trans. Instrumentation and Measurement, 2006, vol 55, no. 2, pp.381-388
- 4 J. S. Yoon, W. R. Eisenstadt, "Embedded loopback for RF ICs", IEEE Trans. Instrumentation and Measurement, 2005, vol. 54, no. 5, pp. 1715-1720
- 5 A. Valdés-García, W. Khalil, B. Bakkaloglu, J. Silva-Martínez, E. Sánchez-Sinencio, "BIST of RF transceiver SoCs: from signal chain to RF synthesizers", Proc. of the IEEE Radio Frequency Integrated Circuits Symposium, 2007.
- 6 D. Han, S. Bhattacharya, A. Chatterjee, "Low-cost parametric test and diagnosis of RF Systems using multi-tone response envelope detection", IET Computers & Digital Techniques, 2007, vol. 1, no. 3, pp. 170-179.
- 7 B. Razavi, "RF Microelectronics" (Prentice Hall PTR, Upper Saddle River, NJ, 1998)
- 8 J. Dugundji, "Envelope and pre-envelopes of real waveforms", IEEE Trans. Infom. Theory, 1958, vol 4, no. 1, pp 53-57.
- 9 D. Vázquez, G. Huertas, A. Luque, M. J. Barragan, G. Leger, A. Rueda, J. L. Huertas, "Sine-wave signal characterization using square-wave and SD-modulation: application to mixed-signal BIST", Journal of Electronic Testing: Theory and Applications, 2005, vol. 21, pp. 221-232.

### Authors' affiliations:

Manuel J. Barragán, Rafaella Fiorelli, Diego Vázquez, Adoración Rueda, José L. Huertas (Instituto de Microelectrónica de Sevilla –IMSE/CNM (CSIC/Universidad de Sevilla), Av. Américo Vespucio s/n, 41092-Seville, SPAIN).

**E-mail:** manuelj@imse.cnm.es

**Figure captions:**

Fig. 1: a) Traditional two-tone test; b) Two-tone response envelope detection.

Fig. 2: Envelope detector model.

**Table captions:**

Table I: Simulation parameters.

Table II: Measurements of the  $B_2/B_1$  ratio as a function of  $M$ .



Figure 1

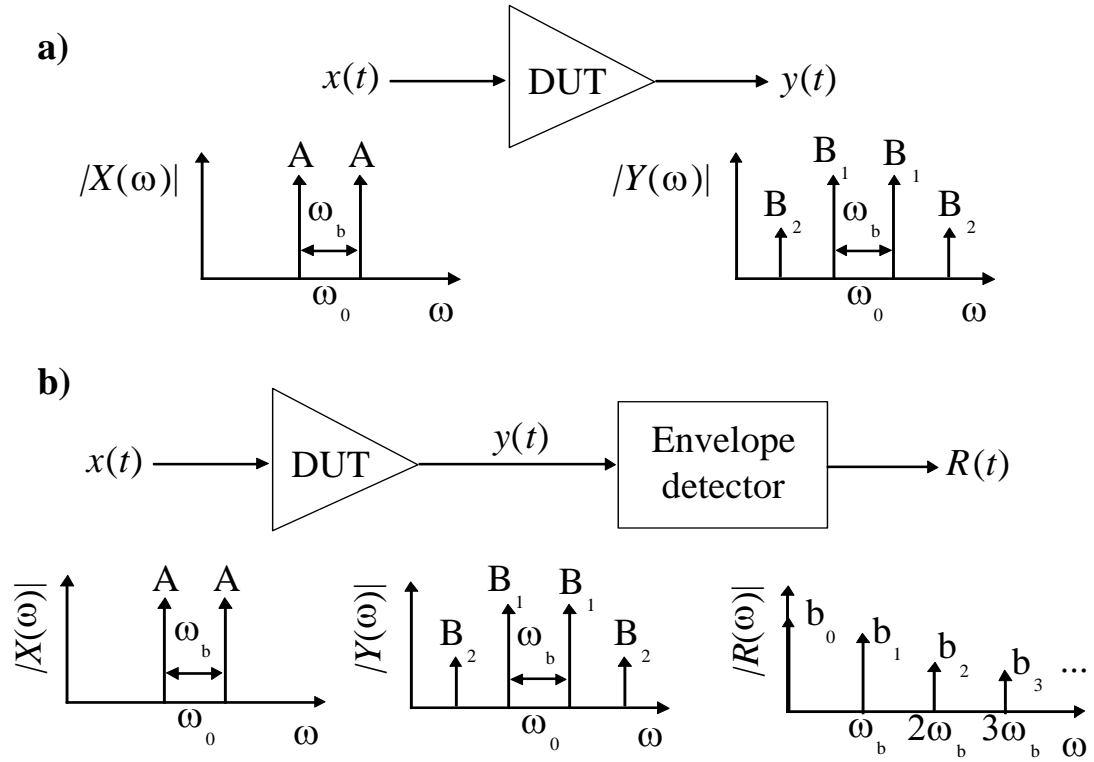

Figure 2

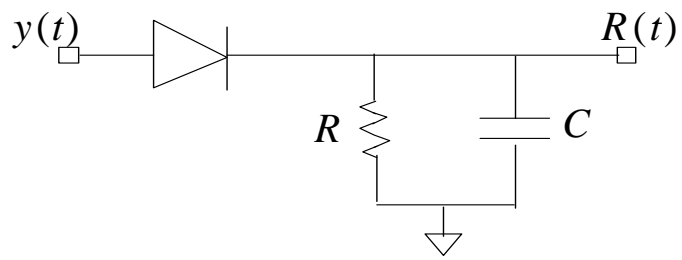

Table I

LNA specifications	Forward gain	16 dB
	Output IP3	34 dBm
	Noise figure	1 dB
SD-modulators	$N$	96
	$FS$	1.2 V
Test stimulus	$A$	100 mV
	$f_0$	1 GHz
	$f_b$	1 MHz

Table II

Evaluation periods, M	Measured $B_2/B_1$	Actual $B_2/B_1$
5	< -36 dB	-56 dB
10	< -42 dB	
20	< -44 dB	
100	[-53 dB, -48 dB]	